



Innovative Torque Solutions

Reell Precision Manufacturing designs and manufactures high quality standard and custom motion control devices that transmit torque, control angular position and protect delicate components from excessive force.

Combining the world's most precisely controlled torque technology, ReellTorq®, with the industry's most experienced engineering team allows Reell to provide a perfect fit solution for your applications.



Reell's elegant and reliable torque solutions are widely used for flat panel and laptop screen positioning, automobile storage and seat hinges, airline and automotive headrests, medical kiosks, office furniture, lighting and much more.



With more than 25 US and international patents and more than 45 years of experience in providing elegant, high-performance product designs for leading global and Fortune 500 companies, Reell products are time tested and proven to solve your positioning needs.



"No one in the world understands small package position control better than Reell"
Reell solves difficult positioning problems



SJ200, SJ300 and SJ500 Spherical Joint

The SJ Series delivers Reell's premium feel and performance in a multi-axis position control device. Featuring Reell's patented SphericalTorq™ technology.

Product Life: 50,000 total adjustments

Available Torques:

SJ200: 0.2, 0.4 N-m

SJ300: 1.0, 2.0 N-m

SJ500: 4.0, 6.0, 8.0 N-m

Torque Symmetry Options:

Symmetric (SJ200)

Differential (SJ300,SJ500)

**A New Dimension
in Position Control!**





ReellTorq®

Discover ReellTorq® Clip Technology

ReellTorq® provides a long-life, cost effective solution for applications requiring constant frictional torque from 0.2 to 11.3 N-m.

The hinge operates by providing torque along the axis of the hinge. A series of clips (1) are pressed onto a shaft (2). The end of the shaft is attached to one side of the hinge (3) and the feet of the clips are attached to the other side of the hinge (4).

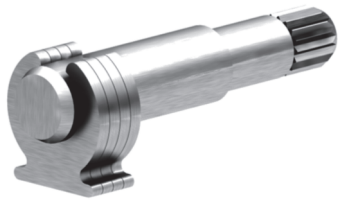
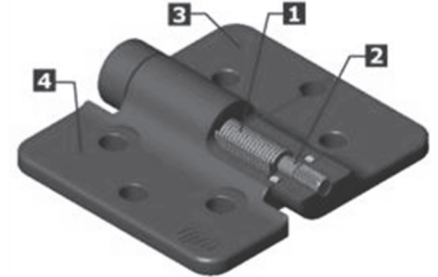

When rotated, the interference between the clips and shaft provides a consistent static and dynamic torque.

Torque increments are achieved through the addition of clips, allowing precise custom torque specifications with standard components.

(Note: example demonstrates Symmetric torque, Differential and One-way torques use slightly differing technology)



Straight



Knurled



Flag

The RT Series

With 15 available size and shaft-end options, and torques from 1.0 to 50.0 lb-in, the RT Series is the most versatile Reell catalog hinge. A fully validated life of 50,000 cycles raises the bar for long-life performance.

Product Life: 50,000 cycles

Available Torques:

RT50: 1.0, 2.0, 3.0, lb-in

RT70: 3.0, 4.0, 5.0, 6.0, 7.0, 8.0 lb-in

RT100: 8.0, 12.0, 16.0, 20.0 lb-in

RT120: 20.0, 30.0, 40.0, 50.0 lb-in

Shaft-end Options:

Flag, Straight, Knurled shaft-end
Dual-ended option (RT-50, RT-70)

Hinge performance tested to 3 times life!

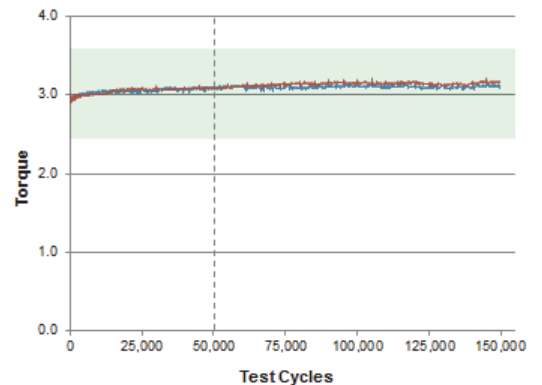

RT-50 RT-70 & RT-100 are available with dual-ended attachment



MH18



MH14



MH12



MH15

Molded Nylon Door Hinges

Lightweight and durable glass-filled nylon provides an attractive clean finish. The MH18 features One-way torque. The MH15 is available in both symmetric and differential torque. At only 15 grams the MH12 weighs one third of a comparable metal hinge.

Product Life: 25,000 cycles (MH12, MH13), 20,000 cycles (MH14, MH15, MH18)

Torque Symmetry Options: Symmetric, Differential (MH15 only), One-way (MH18 only)

Available Torques:

MH12: 0.4, 0.8, 1.2, 1.6 N-m

MH13: 1.0, 2.0, 3.0 N-m

MH14: 1.4, 1.8, 2.2, 2.6, 3.0, 3.4, 3.8, 4.2, 4.6, 5.0, 5.4, 5.8 N-m

MH15: 2.0, 3.0, 4.0, 5.0, 6.0, 7.0, 8.0 N-m

MH18: 4.0, 6.0, 8.0 N-m

Available Colors: Matte Black



MH13

REELL FRICTION HINGES

Explore our interactive hinge application guide at reell.com

Zinc, Aluminum, and Stainless Steel Door Hinges

ReellTorq® performance in a familiar door-hinge configuration.

All hinges have 270° of rotation. The PHCA has a lightweight aluminum bracket, the PHCS features an attractive and corrosion resistant 316 stainless steel bracket, and the PH35 with One-way torque is Reell's highest torque hinge, with torques up to 11.3 N-m.

Product Life: 50,000 cycles (PHC, PHCA, PHCS), 20,000 cycles (others)

Available Torques:

PHL: 0.9, 1.4, 1.8, 2.3, 2.8, 3.4 N-m

PH35: 5.65, 6.78, 7.91, 9.04, 10.17, 11.3 N-m

PHC, PHCA, PHCS: 0.44, 0.78, 1.22, 1.57, 2.01, 2.35, 2.79 N-m

Finish:

PHC, PHL, PH35: Black, Plain (PHC, PHL)

PHCS: 316 Stainless Steel

PHCA: Aluminum

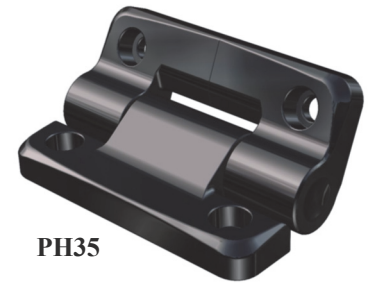
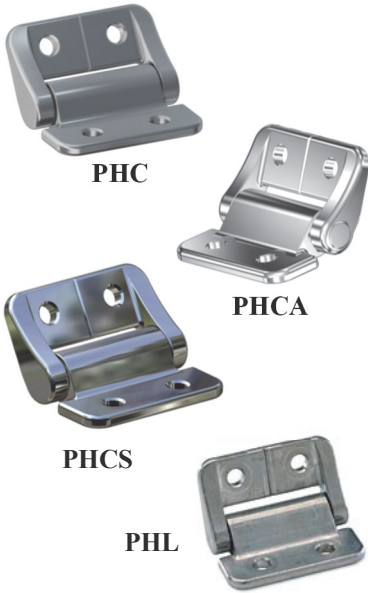

Flag Hinges

Available in a wide variety of mounting configurations and attachment options, flag hinges are among Reell's most versatile and popular hinge offerings. The PHK is available in both single and a dual-ended configurations. The PHT features One-way torque. All flag hinges feature a full 360° of rotation.

Product Life: 50,000 cycles (PHA, PHB), 20,000 cycles (PHK)

Available Torques:

PHA: 0.28, 0.37, 0.46, 0.55, 0.65 N-m

PHB: 0.44, 0.78, 1.22, 1.57, 2.01, 2.35, 2.79 N-m

PHK: 1.5, 2.5, 3.5, 4.5, 5.5 N-m

PHT: 2.0, 4.0, 6.0 N-m

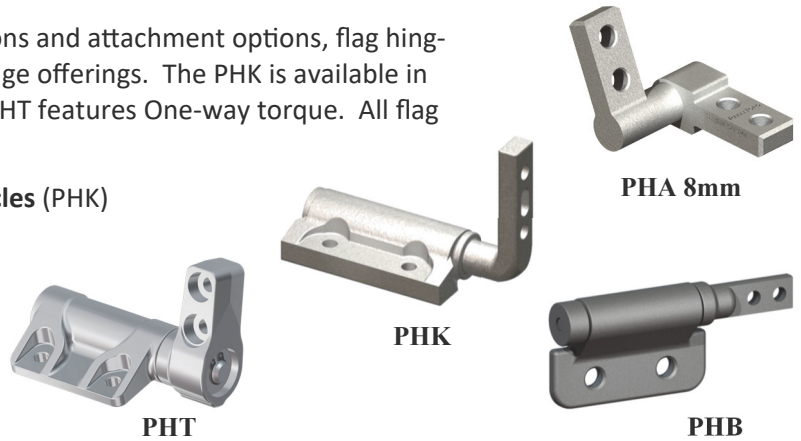

The vTilt VESA Monitor Mount

Attaches directly to either the 75mm or 100mm mounting holes of a standard VESA compliant monitor. At only 5 cm deep, vTilt's compact and clean design has an aesthetically pleasing profile, while the durable nylon housing completely seals all internal components and lubricant.

Product Life: 25,000 cycles

Available Torques:

3.0, 4.0, 5.0, 6.0, 7.0, 8.0 N-m (Differential)

5.0, 6.0, 7.0, 8.0 N-m (One-way)

Torque Symmetry Options: Differential, One-way

Available Colors: Matte Black





REELL TORQUE INSERTS

"Modular Torque Where You Want It"



Designed to be press fit or molded into an assembly without the need for additional mounting hardware, Reell Torque Inserts are a new category of friction hinge. They provide pivoting and positioning without the visible appearance of a hinge. Because they require no fasteners they can be more cost effective and easier to assemble than traditional hinges.

TI-C5M Torque Insert

The TI-C5M is Reell's most compact torque insert. It's 5mm housing makes it ideal for modern consumer electronics applications.



TI-C5M with knurled shaft end



TI-C5M with Single-fin

Product Life: 30,000 cycles

Available Torques: 0.15, 0.25, 0.30 N-m

Torque Symmetry Options: Symmetric

TI-300 Series Torque Inserts

Reell's next generation of torque inserts are available in 3 sizes, with torques from 0.5 to 10.0 N-m. All models feature a powdered metal housing and are available with a single or dual-ended knurled shaft end or with a zinc adapter for press-fit into plastics. All are available with the One-way adapter needed for One-way torque operation.

Product Life: 25,000 cycles

Available Torques:

TI-320: 0.5, 0.75, 1.0, 1.25, 1.5 N-m

TI-340: 2.0, 3.0, 4.0, 5.0 N-m

TI-360: 6.0, 8.0, 10.0 N-m

Torque Symmetry Options:
Symmetric, One-way

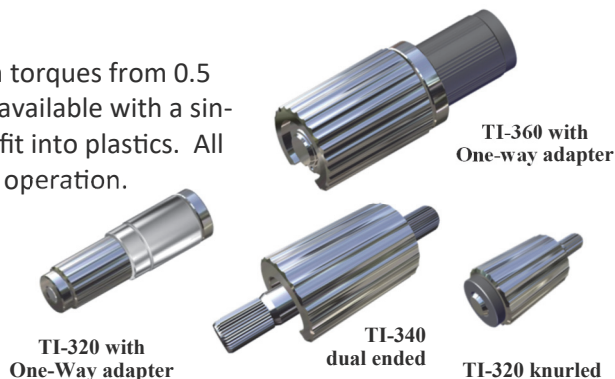

TI-320 with One-Way adapter

TI-340 dual ended

TI-360 with One-way adapter

TI-320 knurled



TI-220

TI-240

TI-200 Series Torque Inserts

Zinc housings are designed for plastic insert over-molding. The TI-200 series features asymmetrical torque, with 100% of the specified torque in one direction and 60% in the opposite direction.

Available Torques:

TI-220: 1.5, 2.0, 2.5, 3.0, 3.5 N-m

TI-240: 2.0, 3.0, 4.0, 5.0, 6.0, 7.0, 8.0 N-m

Torque Symmetry Options: Differential

Product Life: 10,000 cycles (TI-220)
20,000 cycles (TI-240)

TI-100 Series Torque Inserts

Glass-filled nylon housings are designed to be press fit into a variety of materials via a keyed cavity.

Available Torques:

TI-120: 0.25, 0.35, 0.50, 0.65, 0.80, 1.0, 1.2 N-m

TI-130: 1.0, 1.5, 2.0 N-m

TI-140: 1.4, 1.8, 2.2, 2.6, 3.0, 3.4, 3.8, 4.2 N-m

TI-150: 2.0, 3.0, 4.0 N-m

TI-160: 4.0, 5.0, 6.0 N-m



TI-150

TI-120

TI-140

TI-160

TI-150, TI-160 feature One-way torque

TI-120, TI-140 available with single or dual fins

Torque Symmetry Options: Symmetric, One-Way (TI-150, TI-160)

Product Life: 25,000 cycles